

# MG25P12P3 □

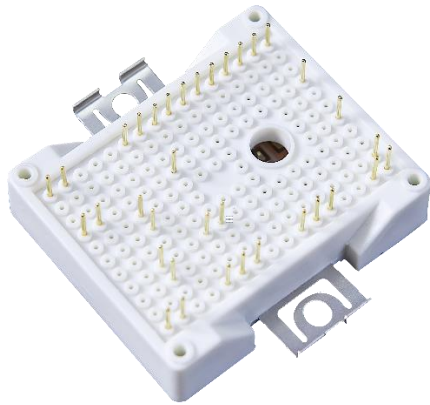

1200V  
25A

Motor Drivers  
AC and DC servo drive amplifier  
UPS (Uninterruptible Power Supplies)

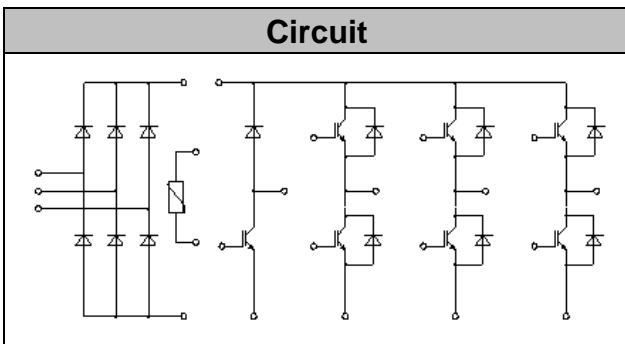

Low switching losses  
Low  $V_{ce(sat)}$  with positive temperature coefficient  
Including fast & soft recovery anti-parallel FWD  
Low inductance case  
High short circuit capability(10us)  
Isolated heatsink using DBC technology  
Maximum junction temperature 175

Collector-Emitter Voltage	$V_{CES}$	$V_{GE}=0V, I_C=1mA, T_{vj}=25$	1200	V
Continuous Collector Current	$I_C$	$T_c=100$ $v_{jmax}$ 175	25	A
Repetitive Peak Collector Current	$I_{CRM}$	$tp=1ms$	50	A
Gate-Emitter Voltage	$V_{GES}$	$T_{vj}=25$	20	V
Total Power Dissipation	$P_{tot}$	$T_c=25$ $T_{vjmax}=175$	175	W

Gate-emitter Threshold Voltage	$V_{GE(th)}$	$V_{GE}=V_{CE}, I_C=1.2mA, T_{vj}=25$	5.2	5.8	6.4	V	
Collector-Emitter Cut-off Current	$I_{CES}$	$V_{CE}=1200V, V_{GE}=0V, T_{vj}=25$			1.0	mA	
Collector-Emitter Saturation Voltage	$V_{CE(sat)}$	$I_C=25A, V_{GE}=15V, T_{vj}=25$		1.85	2.25	V	
		$I_C=25A, V_{GE}=15V, T_{vj}=125$		2.15			
		$I_C=25A, V_{GE}=15V, T_{vj}=150$		2.25			
Gate Charge	$Q_G$			0.20		uC	
Input Capacitance	$C_{ies}$	$V_{CE}=25V, V_{GE}=0V,$ $f=1MHz, T_{vj}=25$		1.90		nF	
Reverse Transfer Capacitance	$C_{res}$			0.10		nF	
Gate-Emitter leakage current	$I_{GES}$	$V_{CE}=0V, V_{GE}=20V, T_{vj}=25$			400	nA	
Turn-on Delay Time	$t_{d(on)}$	$I_C=25A$ $V_{CE}=600V$ $V_{GE}=\pm 15V$ $R_G=20\Omega$ $T_{vj}=25$		26		ns	
Rise Time	$t_r$			17		ns	
Turn-off Delay Time	$t_{d(off)}$			194		ns	
Fall Time	$t_f$			181		ns	
Energy Dissipation During Turn-on Time	$E_{on}$			1.62		mJ	
Energy Dissipation During Turn-off Time	$E_{off}$			1.44		mJ	
Turn-on Delay Time	$t_{d(on)}$		$I_C=25A$ $V_{CE}=600V$ $V_{GE}=\pm 15V$ $R_G=20\Omega$ $T_{vj}=125$		28		ns
Rise Time	$t_r$				21		ns
Turn-off Delay Time	$t_{d(off)}$				284		ns
Fall Time	$t_f$				212		ns
Energy Dissipation During Turn-on Time	$E_{on}$			2.4		mJ	
Energy Dissipation During Turn-off Time	$E_{off}$			2.18		mJ	
SC Data	$I_{sc}$	$T_p \leq 10\mu s, V_{GE}=15V, T_{vj}=150$ , $V_{cc}=900V, V_{CEM} \leq 1200V$			120		A

Repetitive Peak Reverse Voltage	$V_{RRM}$	$T_{vj}=25$	1200	V
Continuous DC Forward Current	$I_F$		25	A
Repetitive Peak Forward Current	$I_{FRM}$	$t_p=1ms$	50	A
$I^2t$ -value	$I^2t$	$V_R=0, t_p=10ms, T_{vj}=125$	90.0	A <sup>2</sup> s
		$V_R=0, t_p=10ms, T_{vj}=150$	75.0	

Forward Voltage	$V_F$	$I_F=25A, T_{vj}=25$		2.10	2.50	V
		$I_F=25A, T_{vj}=125$		2.20		
		$I_F=25A, T_{vj}=150$		2.20		
Recovered Charge	$Q_{rr}$	$I_F = 25 A$		2.52		uC
Peak Reverse Recovery Current	$I_{rr}$	$V_R=600V$ $-di_F/dt = 1700A/us$		28.5		A
Reverse Recovery Energy	$E_{rec}$	$T_{vj}=25$		0.94		mJ
Recovered Charge	$Q_{rr}$	$I_F = 25 A$		50.8		uC
Peak Reverse Recovery Current	$I_{rr}$	$V_R=600V$ $-di_F/dt = 1700A/us$		30.5		A
Reverse Recovery Energy	$E_{rec}$	$T_{vj}=125$		1.75		mJ

# MG25P12P3 □

Collector-Emitter Voltage	$V_{CES}$	$V_{GE}=0V, I_C=1mA, T_{vj}=25$	1200	V
Continuous Collector Current	$I_C$	$T_c=100, v_{jmax} 175$	25	A
Repetitive Peak Collector Current	$I_{CRM}$	$t_p=1ms$	50	A
Gate-Emitter Voltage	$V_{GES}$	$T_{vj}=25$	20	V
Total Power Dissipation	$P_{tot}$	$T_c=25, T_{vjmax}=175$	175	W

Gate-emitter Threshold Voltage	$V_{GE(th)}$	$V_{GE}=V_{CE}, I_C=1.2mA, T_{vj}=25$	5.2	5.8	6.4	V
Collector-Emitter Cut-off Current	$I_{CES}$	$V_{CE}=1200V, V_{GE}=0V, T_{vj}=25$			1.0	mA
Collector-Emitter Saturation Voltage	$V_{CE(sat)}$	$I_C=25A, V_{GE}=15V, T_{vj}=25$		1.85	2.25	V
		$I_C=25A, V_{GE}=15V, T_{vj}=125$		2.15		
		$I_C=25A, V_{GE}=15V, T_{vj}=150$		2.25		
Gate Charge	$Q_G$			0.20		uC
Input Capacitance	$C_{ies}$	$V_{CE}=25V, V_{GE}=0V, f=1MHz, T_{vj}=25$		1.90		nF
Reverse Transfer Capacitance	$C_{res}$			0.10		nF
Gate-Emitter leakage current	$I_{GES}$	$V_{CE}=0V, V_{GE}=20V, T_{vj}=25$			400	nA
Turn-on Delay Time	$t_{d(on)}$	$I_C=25A, V_{CE}=600V, V_{GE}=\pm 15V, R_G=20\Omega, T_{vj}=25$		26		ns
Rise Time	$t_r$			17		ns
Turn-off Delay Time	$t_{d(off)}$			194		ns
Fall Time	$t_f$			181		ns
Energy Dissipation During Turn-on Time	$E_{on}$			1.62		mJ
Energy Dissipation During Turn-off Time	$E_{off}$			1.44		mJ

# MG25P12P3 □

Turn-on Delay Time	$t_{d(on)}$	$I_C = 25\text{ A}$ $V_{CE} = 600\text{ V}$ $V_{GE} = \pm 15\text{ V}$ $R_G = 20\ \Omega$ $T_{vj} = 125$	28	ns
Rise Time	$t_r$		21	ns
Turn-off Delay Time	$t_{d(off)}$		284	ns
Fall Time	$t_f$		212	ns
Energy Dissipation During Turn-on Time	$E_{on}$		2.4	mJ
Energy Dissipation During Turn-off Time	$E_{off}$		2.18	mJ
SC Data	$I_{sc}$		$T_p \leq 10\ \mu\text{s}, V_{GE} = 15\text{ V}, T_{vj} = 150$ , $V_{cc} = 900\text{ V}, V_{CEM} \leq 1200\text{ V}$	120

Repetitive Peak Reverse Voltage	$V_{RRM}$	$T_{vj} = 25$	1200	V
Continuous DC Forward Current	$I_F$		15	A
Repetitive Peak Forward Current	$I_{FRM}$	$t_p = 1\text{ ms}$	30	A
$I^2t$ -value	$I^2t$	$V_R = 0, t_p = 10\text{ ms}, T_{vj} = 125$	16.0	A <sup>2</sup> s
		$V_R = 0, t_p = 10\text{ ms}, T_{vj} = 150$	14.0	

Forward Voltage	$V_F$	$I_F = 15\text{ A}, T_{vj} = 25$	2.00	2.65	V
		$I_F = 15\text{ A}, T_{vj} = 125$	2.10		
		$I_F = 15\text{ A}, T_{vj} = 150$	2.10		
Recovered Charge	$Q_{rr}$	$I_F = 15\text{ A}$	1.20		$\mu\text{C}$
Peak Reverse Recovery Current	$I_{rr}$	$V_R = 600\text{ V}$ $-di_F/dt = 600\text{ A}/\mu\text{s}$	13.0		A
Reverse Recovery Energy	$E_{rec}$	$T_{vj} = 25$	0.37		mJ
Recovered Charge	$Q_{rr}$	$I_F = 15\text{ A}$	2.05		$\mu\text{C}$
Peak Reverse Recovery Current	$I_{rr}$	$V_R = 600\text{ V}$ $-di_F/dt = 600\text{ A}/\mu\text{s}$	12.0		A
Reverse Recovery Energy	$E_{rec}$	$T_{vj} = 125$	0.68		mJ



# MG25P12P3

---

# MG25P12P3 □

Isolation voltage	$V_{isol}$	$t=1min, f=50Hz$	2500			V
Maximum Junction Temperature	$T_{jmax}$				175	
Operating Junction Temperature	$T_{vjop}$		-40		150	
Storage Temperature	$T_{stg}$		-40		125	
Stray-inductance-module	$L_{SCE}$			30		
Module lead resistance, terminals-chip	$R_{cc+EE'}$	$T_C=25$ , per switch		5.00		
	$R_{AA+CC'}$			6.00		
Thermal Resistance Junction-to Case	$R_{JC}$ to Case	per IGBT-inverter		0.75	0.85	
		per Diode-inverter		1.10	1.20	

Thermal Resistance  
Junction-to Case

$R_{JC}$  to Case per IGBT

K/W

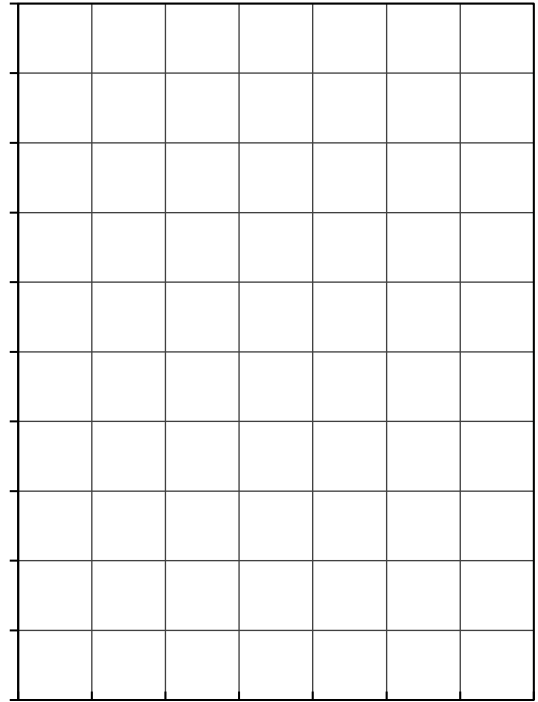
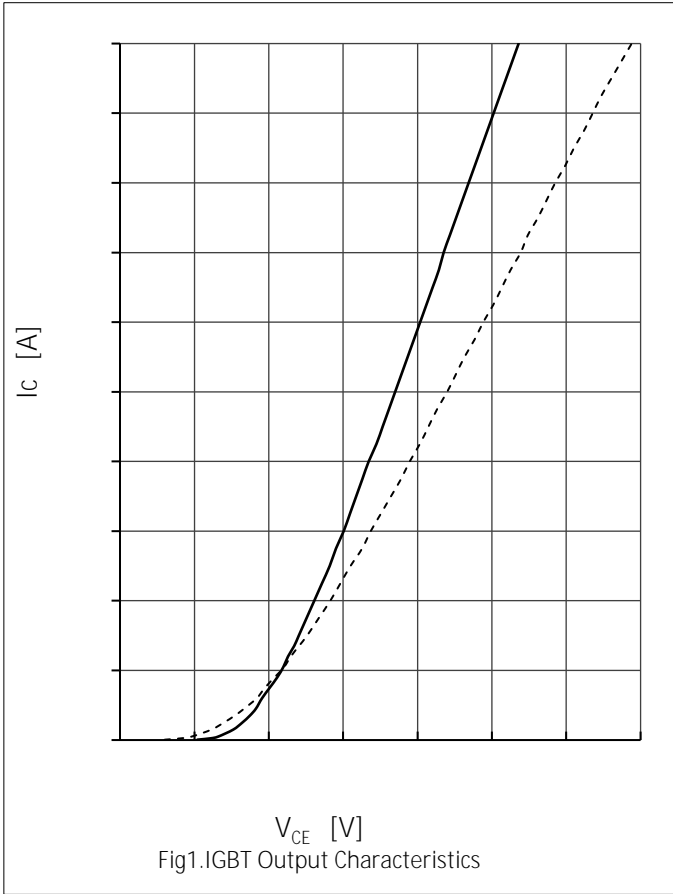



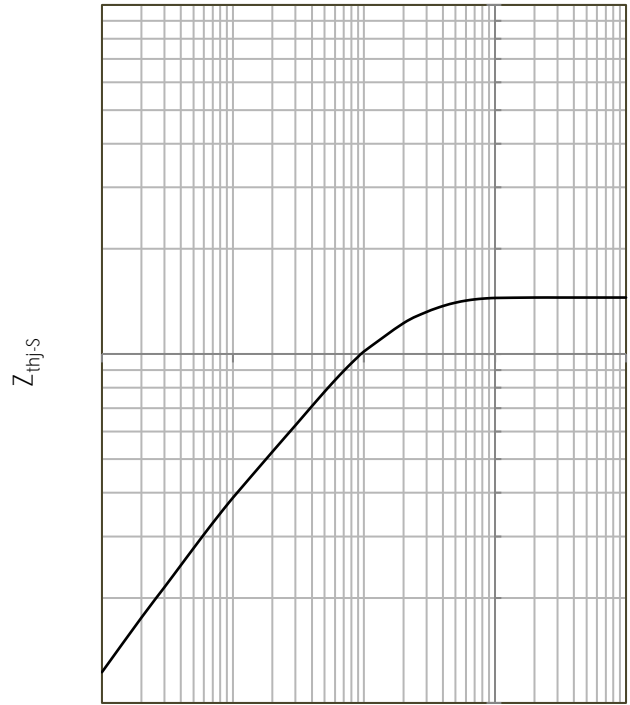
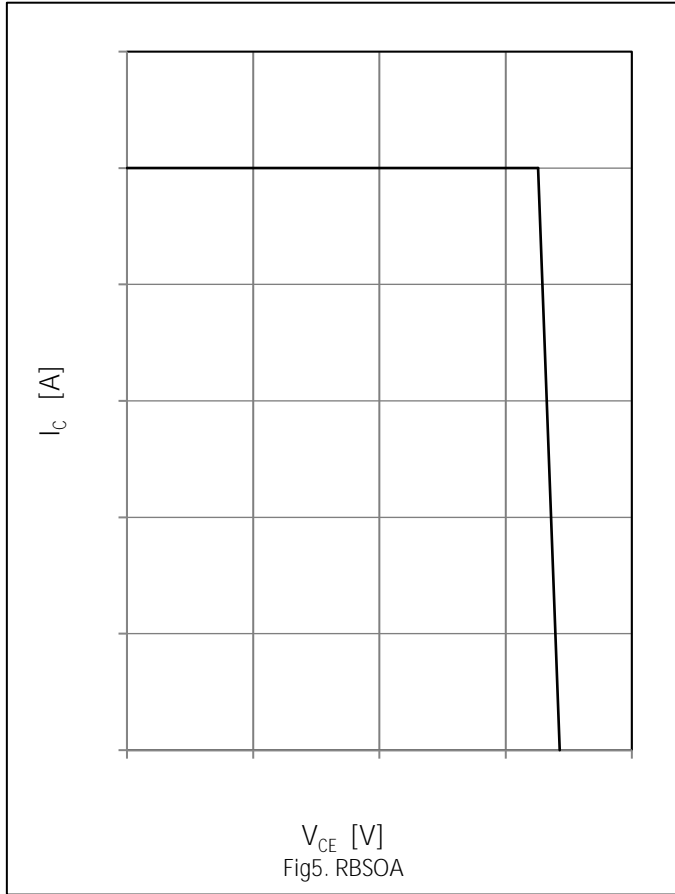

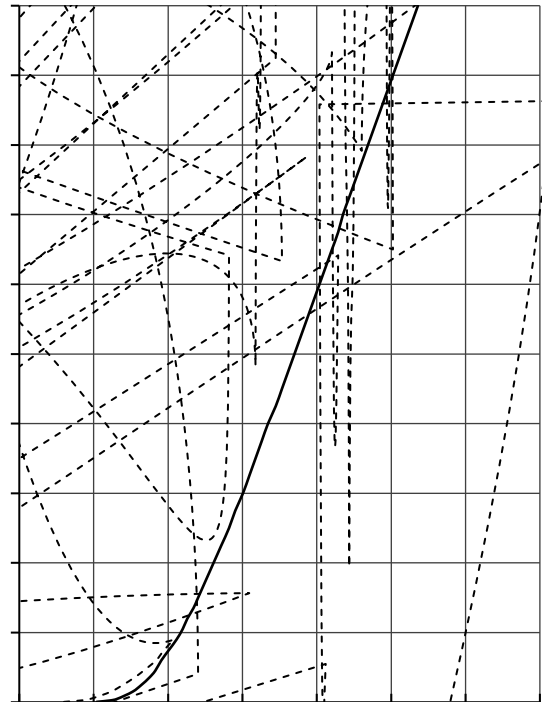
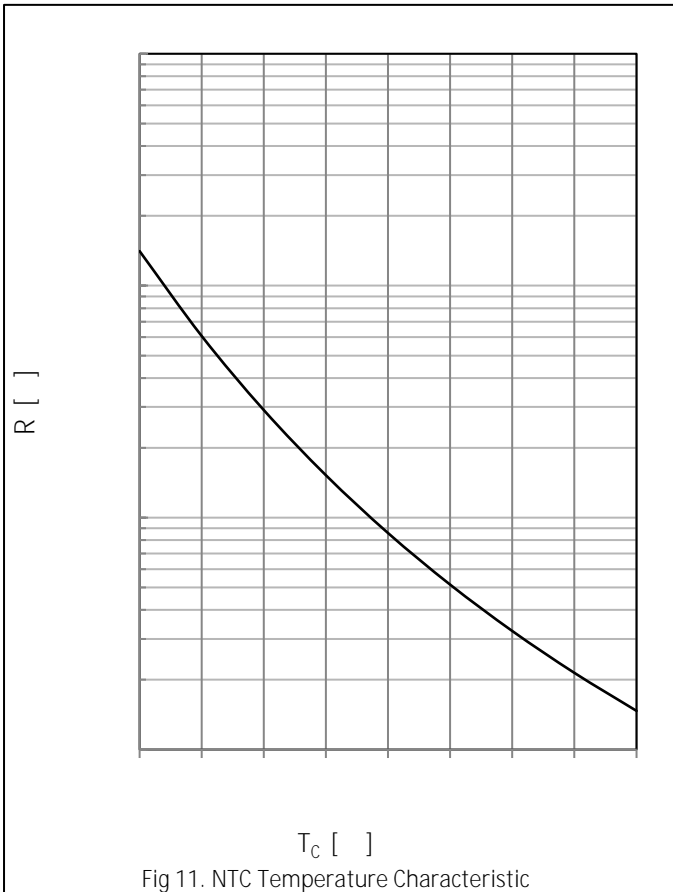
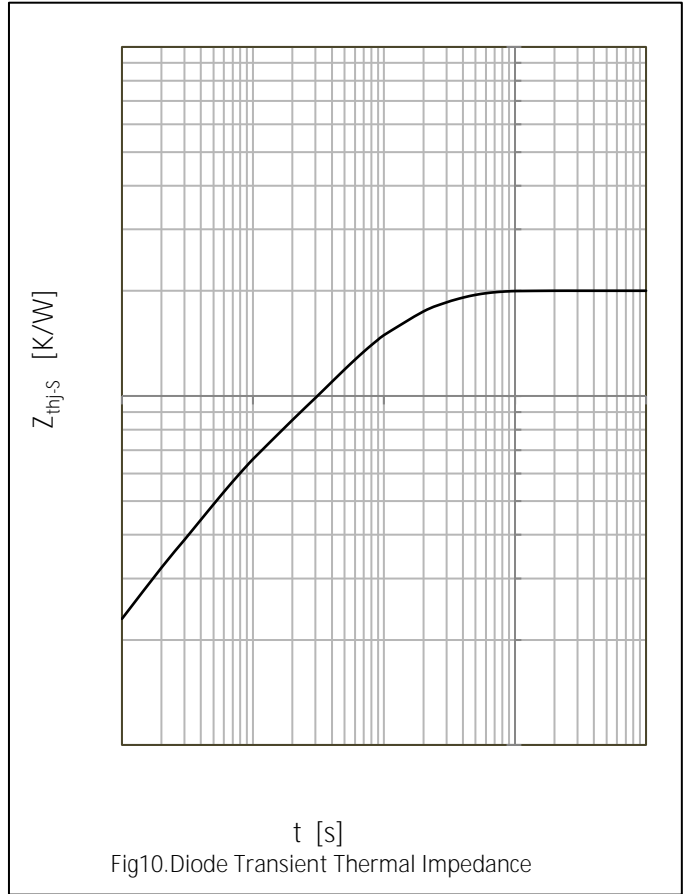
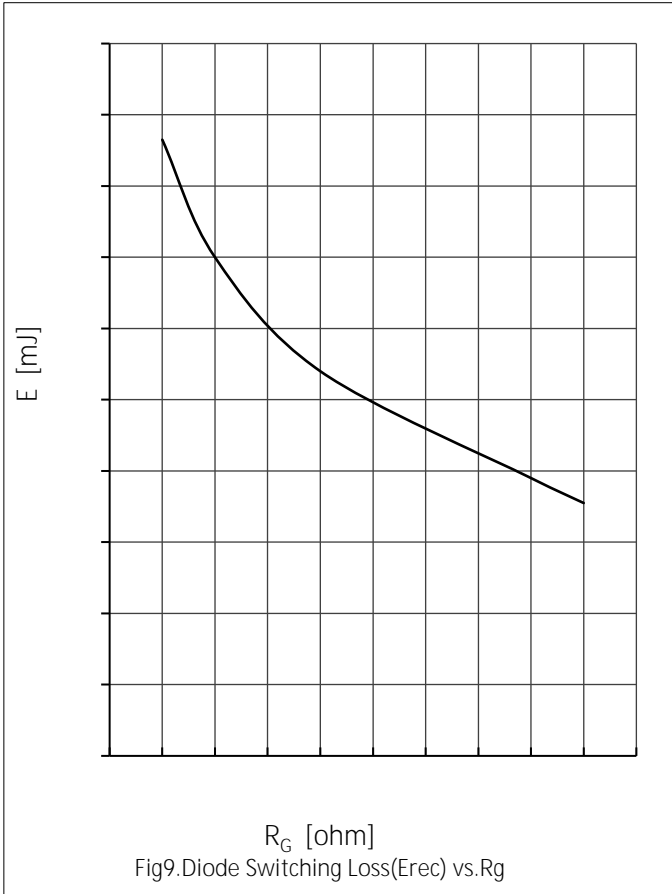

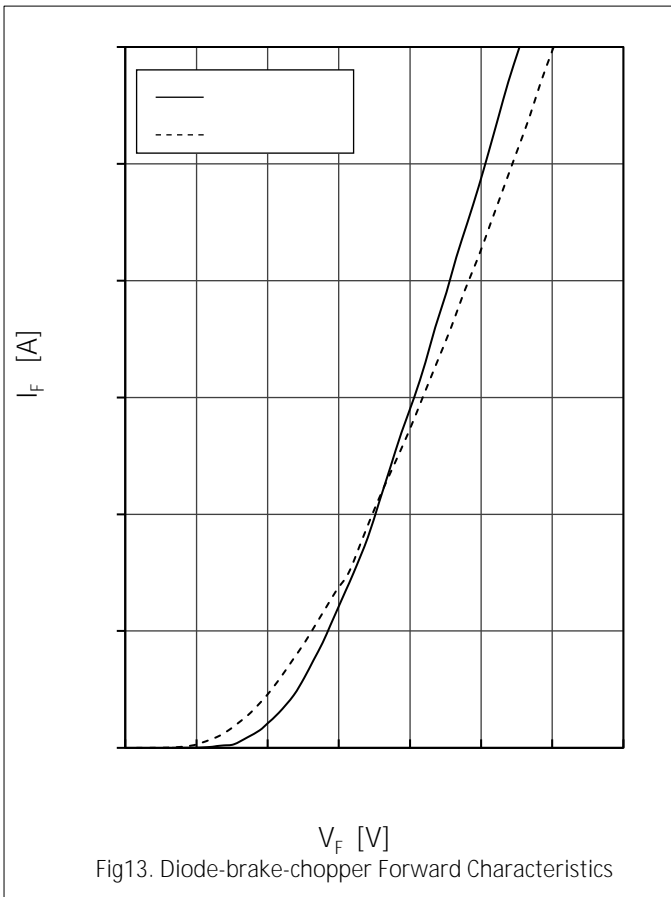

# MG25P12P3

