

12W

-
- EMI
-
- 4KV ESD
-
-
-
- 85V 265V
- 700V
-
-
- 65KHz PWM
-
-

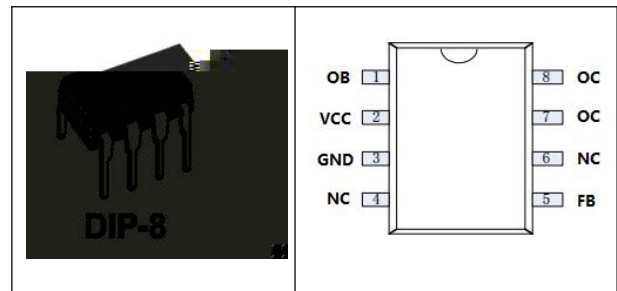

		OC
		10uF 100uF
		1nF 10nF

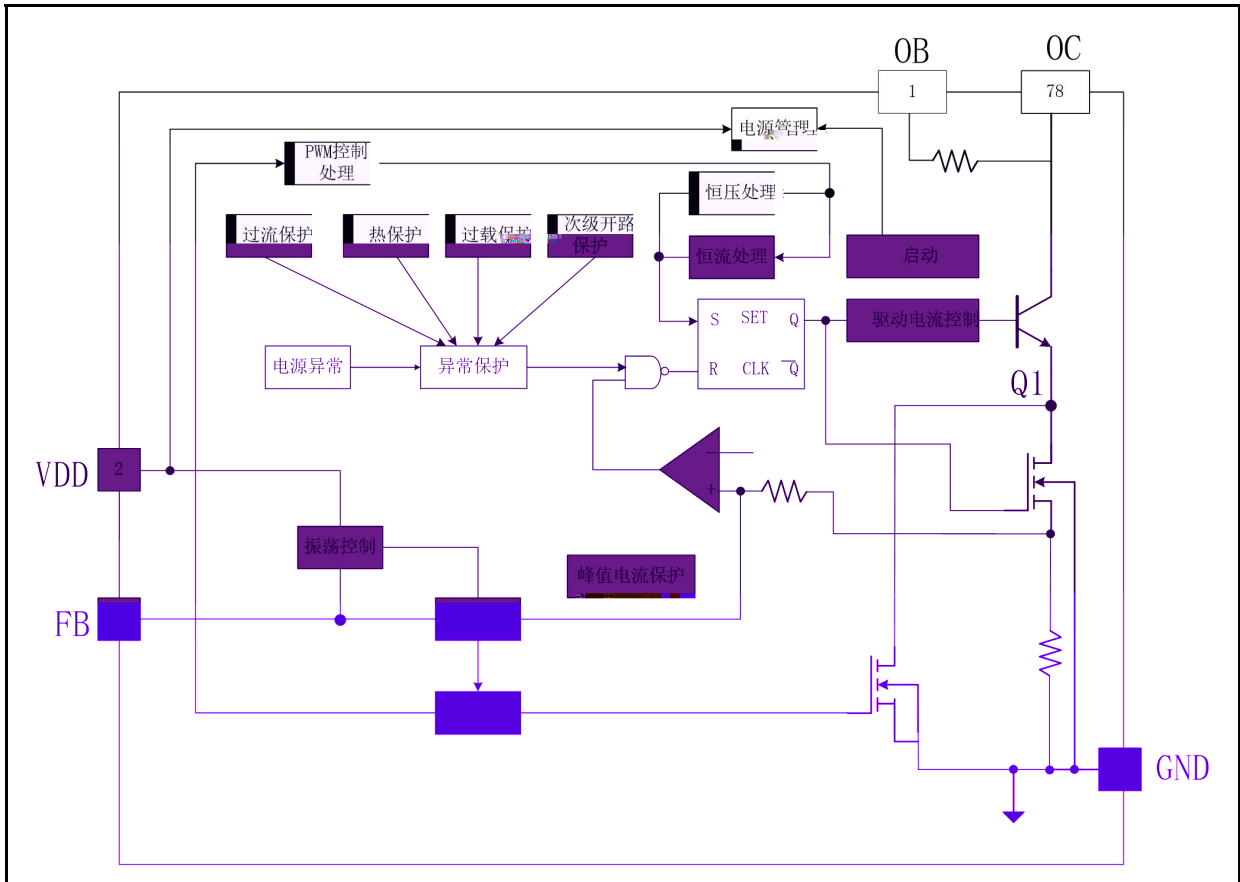

VCC	AC	85V-----265V			
VCC	AC	85V-----265V			
VCC	AC	85V-----265V			
	AC	85V-----265V			
PWM					

PWM

π

FB

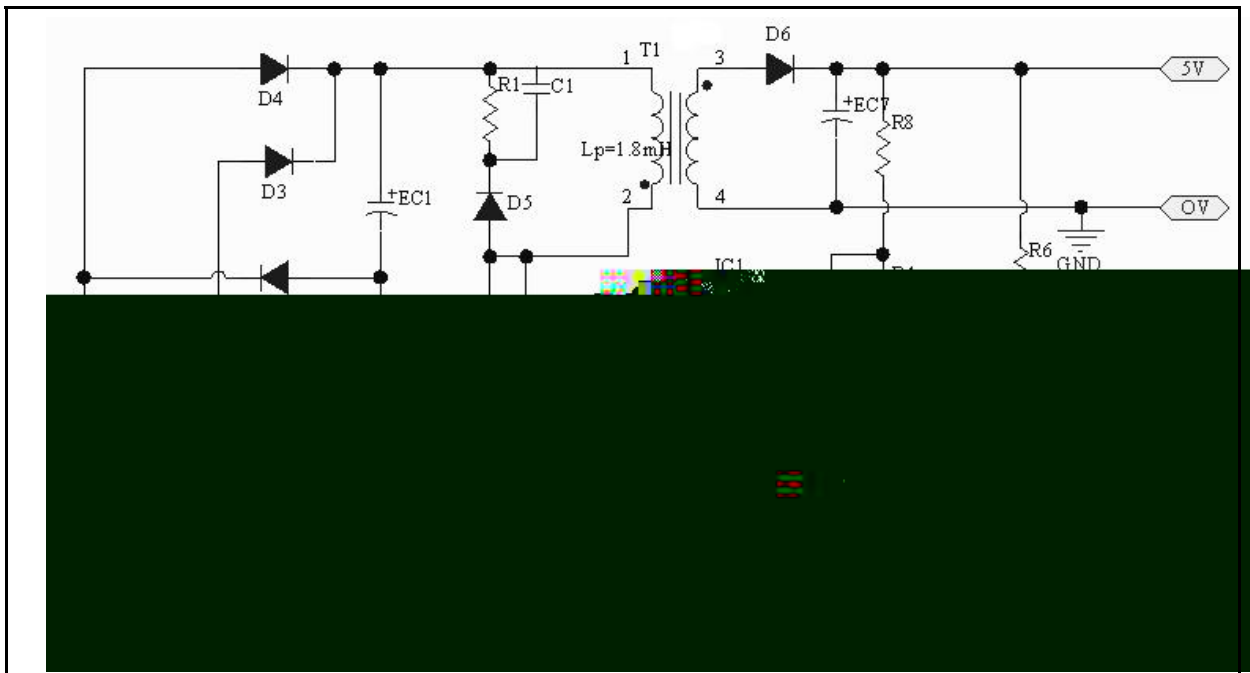

DIP-8

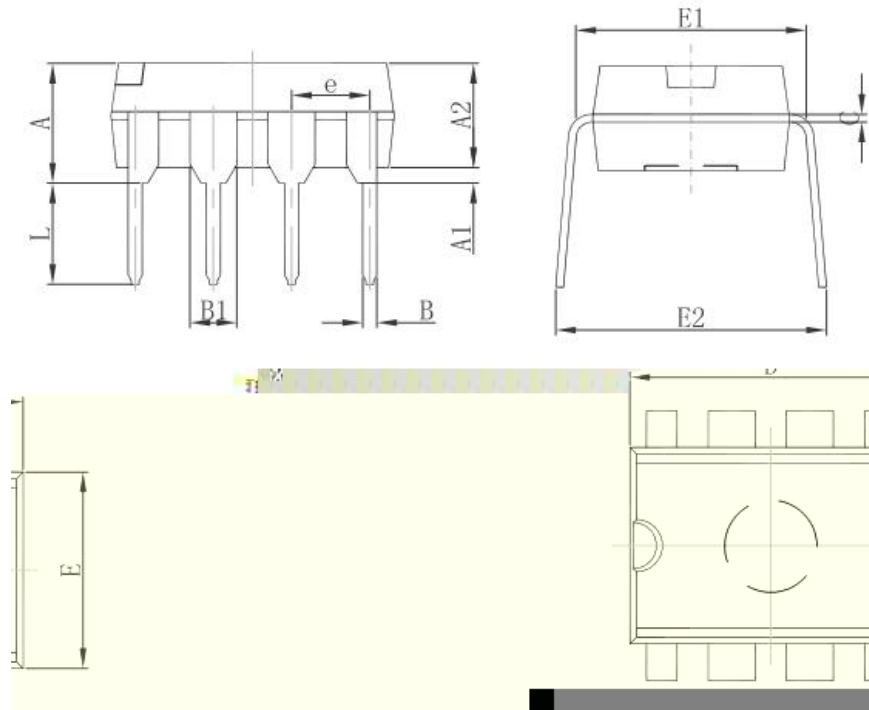

Symbol	Dimensions In Millimeters		Dimensions In Inches	
	Min	Max	Min	Max
A	3.710	4.310	0.146	0.170
A1	0.510		0.020	
A2	3.200	3.600	0.126	0.142
B	0.380	0.570	0.015	0.022
B1	1.524(BSC)		0.060(BSC)	
C	0.204	0.360	0.008	0.014
D	9.000	9.400	0.354	0.370
E	6.200	6.600	0.244	0.260
E1	7.320	7.920	0.288	0.312
e	2.540(BSC)		0.100(BSC)	
L	3.000	3.600	0.118	0.142
E2	8.400	9.200	0.331	0.354

2.

DI P-8

SCP-8

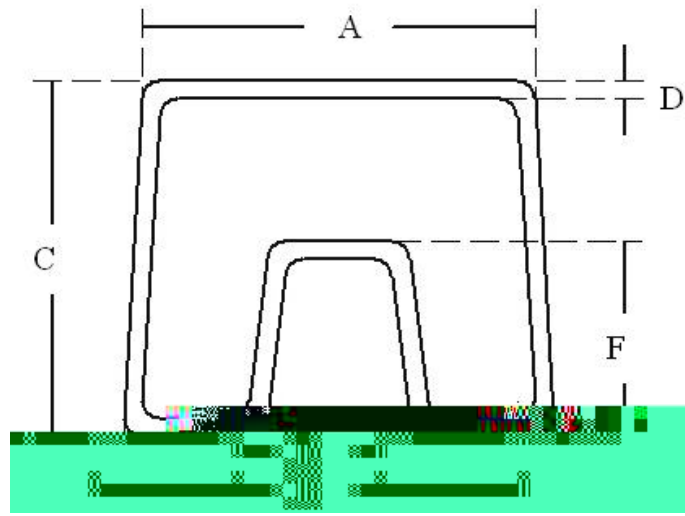

Symbol	Dimension In Millimeters
Mi	



-
-
-
-
-
-
-

-