

SB7560S 75A SCRs

FEATURES

- High thermal rating and performance
- High voltage capacity
- Very high current surge capability

APPLICATIONS

- Line rectifying 50/60 Hz
- Softstart AC motor control
- DC Motor control
- Power converter
- AC power control
- Lighting and temperature control

Parameters Summary

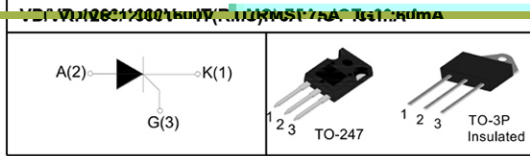

ABSOLUTE MAXIMUM RATINGS

Parameter	Symbol	Value	Unit
Storage junction temperature range	T _{stg}	-40~150	°C
Operating junction temperature range	T _j	-40~125	°C
Repetitive peak on-state voltage (T=25°C)	V _{DRM}	1200/1000	V
Repetitive peak reverse voltage (T=25°C)	V _{KRM}	1200/1000	V
Non repetitive surge peak Off-state voltage	V _{DSM}	V _{DRM} +100	V
Non repetitive peak reverse voltage	V _{AKSM}	V _{KRM} +100	V
RMS on-state current (T=100°C)	I _{T(RMS)}	75	A
Non repetitive surge peak on-state current	I _{TSM}	700	A
I ² t value for fusing (tp=10ms)	I ² t	2450	A ² s
Critical rate of rise of on-state current (I=2×IGT, tr ≤ 100 ns)	di/dt	150	A/μs
Peak gate current	I _{GM}	5	A
Average gate power dissipation	P _{G(AV)}	2	W

Thermal Resistances

Symbol	Parameter	Value	Unit
R _{th(j-c)}	Junction to case (DC)	TO-3P	°C/W
		TO-247	

ELECTRICAL CHARACTERISTICS (T=25°C unless otherwise specified)

Symbol	Test Condition	Value
V_{GT}	$V_{GT} = 12V$ $R = 140\Omega$	1.0V
V_{GT}	$V_D = V_{DRM}$ $T_i = 125^\circ C$ $R = 1K\Omega$	1.0V
I_T	$I_G = 1.2I_{GT}$ $I_T = 0.01A$	300mA
α	$V_D = 12V$ $V_{GT} = 12V$ $R = 140\Omega$ $I_T = 1.2I_{GT}$	0.95

STAT CHARACTERISTICS

Symbol	Parameter	Value
V_{TM}	$I_{TM} = 140A$ $t_p = 380\mu s$	$T_i = 25^\circ C$
I_{DRM}	$V_D = V_{DRM}$ $V_{GT} = V_{GT}$	$T_i = 125^\circ C$
I_{RRM}		$T_i = 125^\circ C$

Ordering Information Scheme

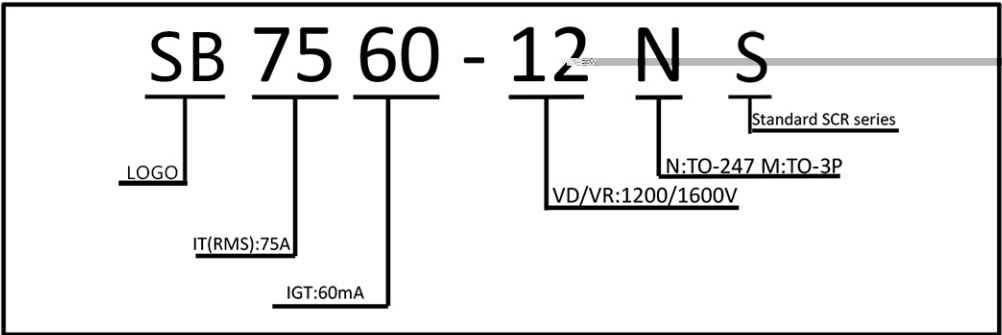

TO-247 Package Mechanical Data

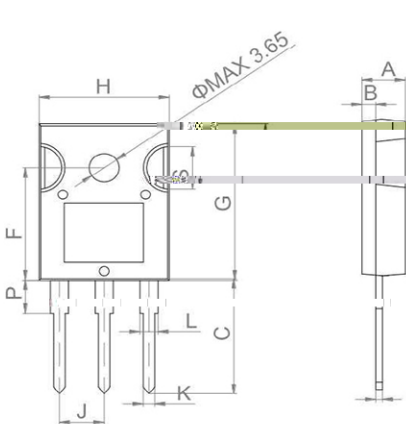

Ref.	Dimension	Value
A
B
C
D
F
G
H
J
K
P
S

TO-3P Package Mechanical Data

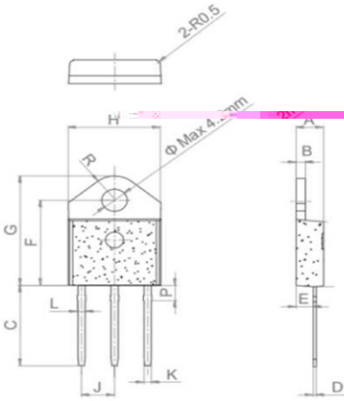

Ref.	Dimensions					
	Millimeters			Inches		
	Min.	Typ.	Max.	Min.	Typ.	Max.
A	4.40		4.60	0.173		0.181
B	1.40		1.60	0.055		0.062
C	15.48		15.88	0.609		0.625
D	0.50		0.70	0.019		0.027
E	2.70		2.90	0.106		0.114
F	15.92		16.32	0.626		0.642
G	20.27		20.67	0.802		0.814
H	15.15		15.35	0.590		0.604
J		5.45		0.214		0.216
K	1.10		1.30	0.043		0.051
L	1.15		1.35	0.045		0.053
P	2.68		3.08	0.105		0.121
R		4.20		0.165		

FIG.1 Maximum power dissipation versus on-state current

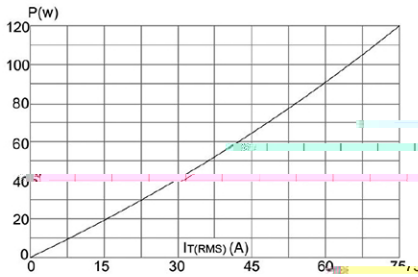

FIG.2: on-state current versus case temperature

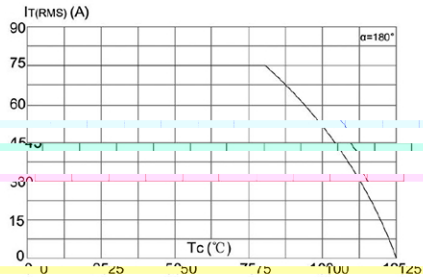

FIG.3: Surge peak on-state current versus number of cycles

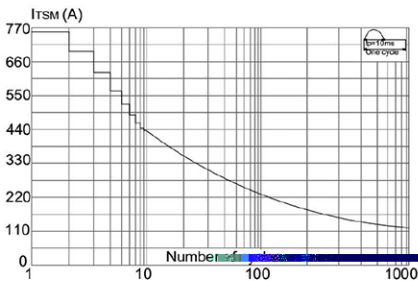

FIG.4: On-state characteristics (maximum values)

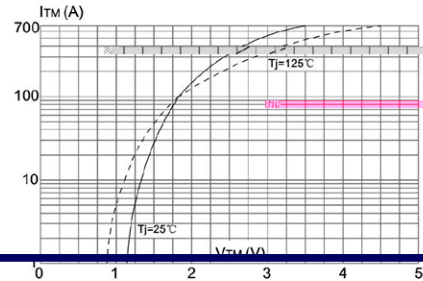

FIG.5: Non-repetitive surge peak on-state current for a sinusoidal pulse with width $t_p < 10\text{ms}$, and corresponding value of $I_2 t$ ($di/dt < 50\text{A}/\mu\text{s}$)

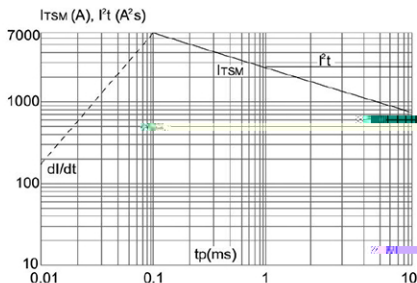

FIG.6: Relative variations of gate trigger current, holding current and latching current versus junction temperature

